

B10 | **Operation manual**

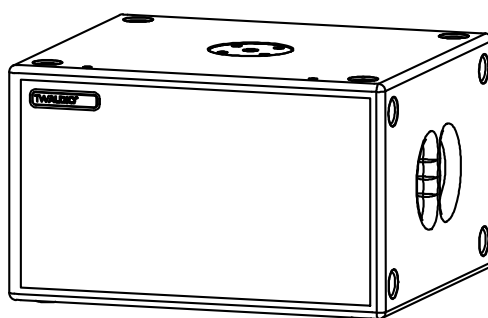

Introduction

Thank you for choosing a high-quality product “MADE IN GERMANY” from TWAUDIÖ.

A sudden impact in depth paired with an exactly defined sound – this is what “bass” sounds like.

The dimensions of our “smallest” let not assume such a performance. But the B10 wouldn't be a TWAUDIÖ sub if it hadn't more to offer: Its newly developed long excursion cone driver with an uncompromising 3“ dual voice coil and optional passive cross-over with switchable high-pass outputs enable the standard bi-amp mode amongst numerous other passive applications:

One single B10 in stereo mode together with two C5 tops, two B10 switched to mono each with one M8, or four B10 together with two M10, all variations powered by one standard amplifier.

If you lend your product to another party, inform that party of the safety-related operating procedures and hand over this assembly guide. If you require additional copies of this manual, you can obtain them free of charge from TWAUDIÖ or download them from www.twaudio.de

Instructions in this user manual

Strictly adhere to the instructions contained in this operating manual that are marked as follows:



This symbol in combination with the signal word “Warning” identifies a potentially hazardous situation. Failure to comply with this safety instruction can lead to serious injury or even death.



This symbol in combination with the signal word “Warning” identifies a potentially hazardous situation for persons with a pacemaker. Failure to comply with this safety instruction can lead to serious injury or even death.



This symbol in combination with the signal word “Caution” identifies a potentially hazardous situation. Failure to comply with this safety instruction can lead to light or moderate injury.



This symbol in combination with the signal word “Note” identifies a potentially hazardous situation. Failure to comply with this safety instruction can lead to product damage.



This symbol in combination with the signal word “Tip” identifies additional information or notes that will simplify working with TWAUDIO products on the basis of practical experience.

**Read manual
before use!**

Notes on the products

Before using the device, carefully read the operating manual and keep it with the B10 loudspeaker.

General information

Operation manual: OM-B10
Version 1.1 en, 11/2018
© by TWAUDIÖ 2018; all rights reserved.

All information contained in this operating manual was correct to the best of our knowledge at the time of printing.

Quality warranties or assurance of suitability for a certain type of use based on the technical specifications, dimensions and weights are not granted by TWAUDIÖ.

TWAUDIÖ also shall not assume liability for any secondary damage (property damage and/or personal injury) nor for the failure to comply with this operating manual!

TWAUDIÖ reserves the right to update this document based on recent developments.

TWAUDIÖ GmbH
Osterholzallee 140
71636 Ludwigsburg
Germany

Phone : + 49 (0) 71 41-48 89 89 0
Fax: + 49 (0) 71 41-48 89 89 99
E-Mail: info@twaudio.de
WWW: www.twaudio.de

Content

1. Safety Intended use.....	5
2. Overview	7
2.1 Components	7
2.2 Variants	8
2.2.1 B10A / B10P model	8
2.3 Operation modes.....	9
2.3.1 Selector switch S3 - MONO/STEREO mode	9
2.3.2 Selector switch S1 and S2 - TOP OUTPUT mode	10
3. Technical data	11
3.1 Data sheet.....	11
3.2 Connection diagram	11
3.2.1 Variant: B10A	11
3.2.2 Variant: B10P	12
4. Commissioning.....	13
4.1 Setup	13
4.2 M20 pole mount flange.....	13
4.3 Operation	16
4.4 Connecting the cable.....	16
5. Transport and storage	17
6. CE Conformity Declaration.....	18
7. Disposal	19

1. Safety | Intended use

Please adhere to the following safety instructions to avoid risks when operating loudspeakers.

The B10 loudspeaker was developed for use in professional sound systems. The loudspeaker may only be used by trained and qualified personnel.

Note the operating modes described in this operating manual. Other uses are not permissible.

Damage caused by improper use is not covered by TWAUDIÖ.



Loudspeakers generate an electromagnetic field. Persons with pacemakers are not permitted to remain in the immediate vicinity of loudspeakers as the electromagnetic fields can cause pacemakers to malfunction.



When working with heavy loads exceeding 20 kg (44,09 lbs.), use suitable aids (dollies, hoisting slings, etc.). Multiple persons may be required depending on the situation.

Ensure that the units are in a stable position and are firmly attached. A falling loudspeaker can result in serious personal injury and property damage.

When using and assembling TWAUDIÖ loudspeakers, only use materials specified by TWAUDIÖ. These tasks must be performed by qualified personnel. Adhere to the applicable safety regulations.



When setting up loudspeakers, ensure that they are not exposed to the following ambient conditions:

- direct sunlight
- Humidity
- Jolting
- Dust



Keep away from the immediate vicinity of loudspeakers that are operated at high sound pressure levels. These loudspeaker systems are capable of endangering your health. Sound levels beginning as low as approximately 90 dB SPL can lead to long-term hearing impairment.



Avoid:

- Feedback
- Distorted signals (clipping) and
- Peaks resulting from switching on devices, plugging in devices or unplugging devices during operation.

Such signals can lead to loudspeaker overload and ultimately to loudspeaker failure.



Ensure that the loudspeaker is not exposed to permanent thermal overloads. Thermal overloads may cause a fire and result in serious personal injury and property damage.

Note that TWAUDIÖ does not provide a warranty for damage that can be attributed to this type of overload and therefore cannot be held liable for any secondary damage.



A permanent magnetic field is present in the immediate vicinity of loudspeakers. Ensure that objects which react sensitively to magnetic fields are not located in the immediate vicinity of the loudspeaker. In particular, this applies to magnetic storage media, magnetic stripe cards such as debit cards and CRT displays. A distance of approximately one meter is sufficient to avoid damage.



Check loudspeakers and accessory parts regularly for visible wear. This is essential to ensure continuing fault-free operation. Worn parts should be replaced immediately. Spare parts are available from TWAUDIÖ.

2. Overview

2.1 Components

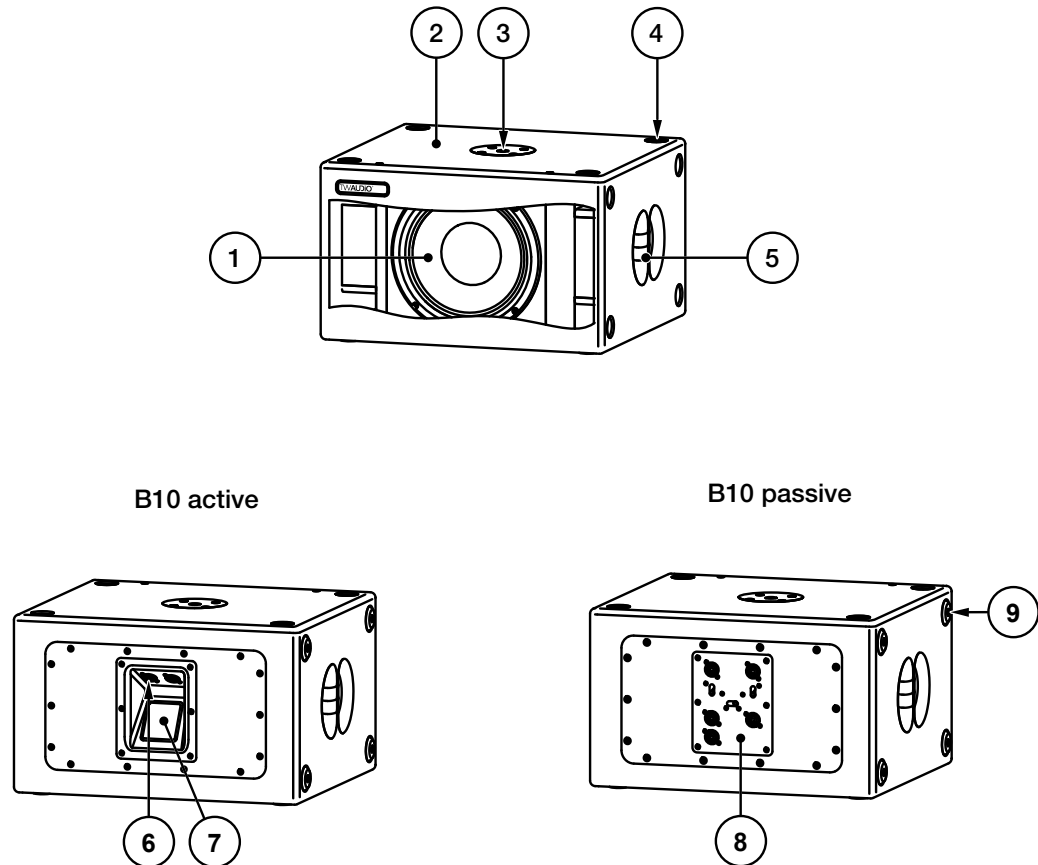

Figure 2.1 - Overview

1. 10" cone driver
2. 15 mm multiplex housing – Warnex texture paint surface finish
3. M20 pole mount flange for attaching a distance rod
4. Milling for rubber feet for safely stacking loudspeakers
5. Ergonomic carrying handle (top and bottom)
6. Standard connection panel
7. Type label
8. PWB10 passive crossover
9. Rubber feet (8 pieces)

2.2 Variants

The B10 loudspeaker comes in two different variants. The distinction is between the B10A (ACTIVE model) and B10P (PASSIVE model).

2.2.1 B10A / B10P model

The standard version of the B10 loudspeaker is the B10A variant which can only be operated in „ACTIVE“ mode. It comes with a standard connection panel. The separation takes place in the amplifier DSP.

The B10P version can be used either passively (using the “MONO” and “STEREO” operating modes) or active with the corresponding preset.

The integrated passive crossover (item 8 “Figure 2.1 - Overview” on page 7.) has three selector switches that are described in the following chapter.

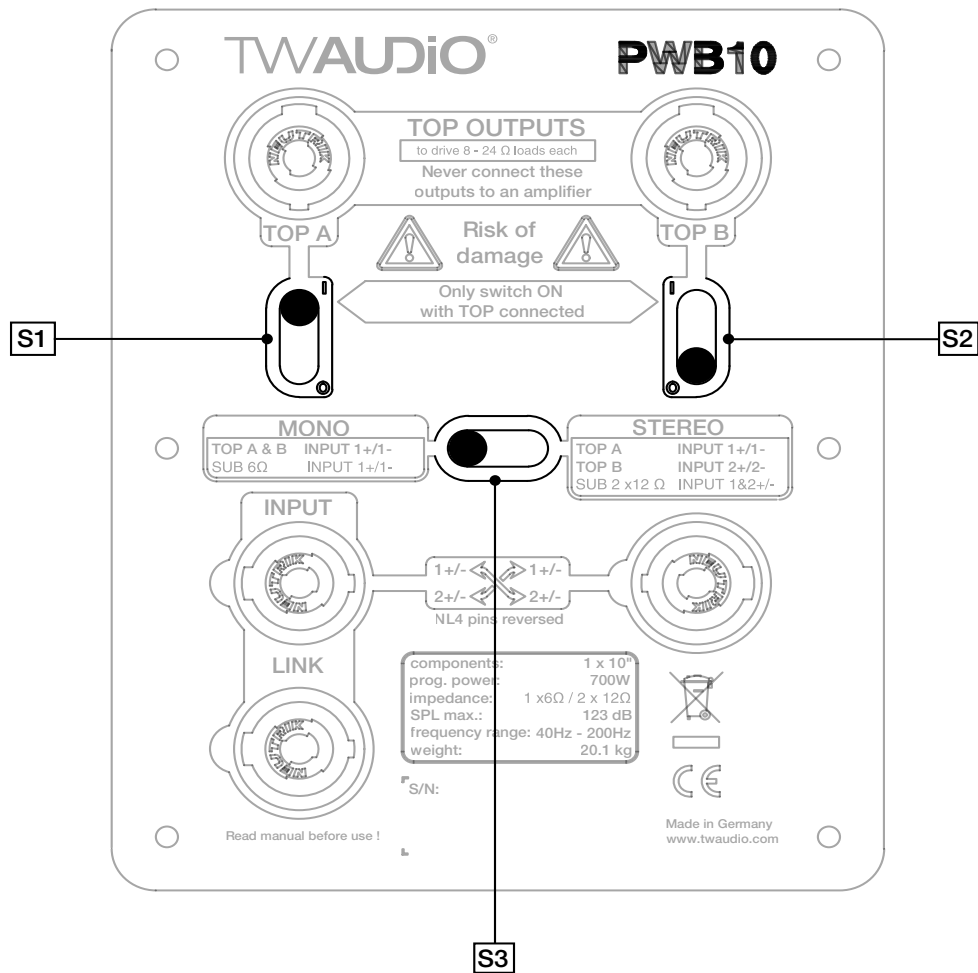

Figure 2.2 - Overview selector switches

2.3 Operation modes

2.3.1 Selector switch S3 - MONO/STEREO mode

One input channel is required for operation in „MONO“ mode.



1. Connect the top loudspeaker to the high pass output (TOP A)!
Never connect an amplifier to this connector!
2. Switch the switch S3 to „MONO“.
3. Switch the switch S1 to „ON“.

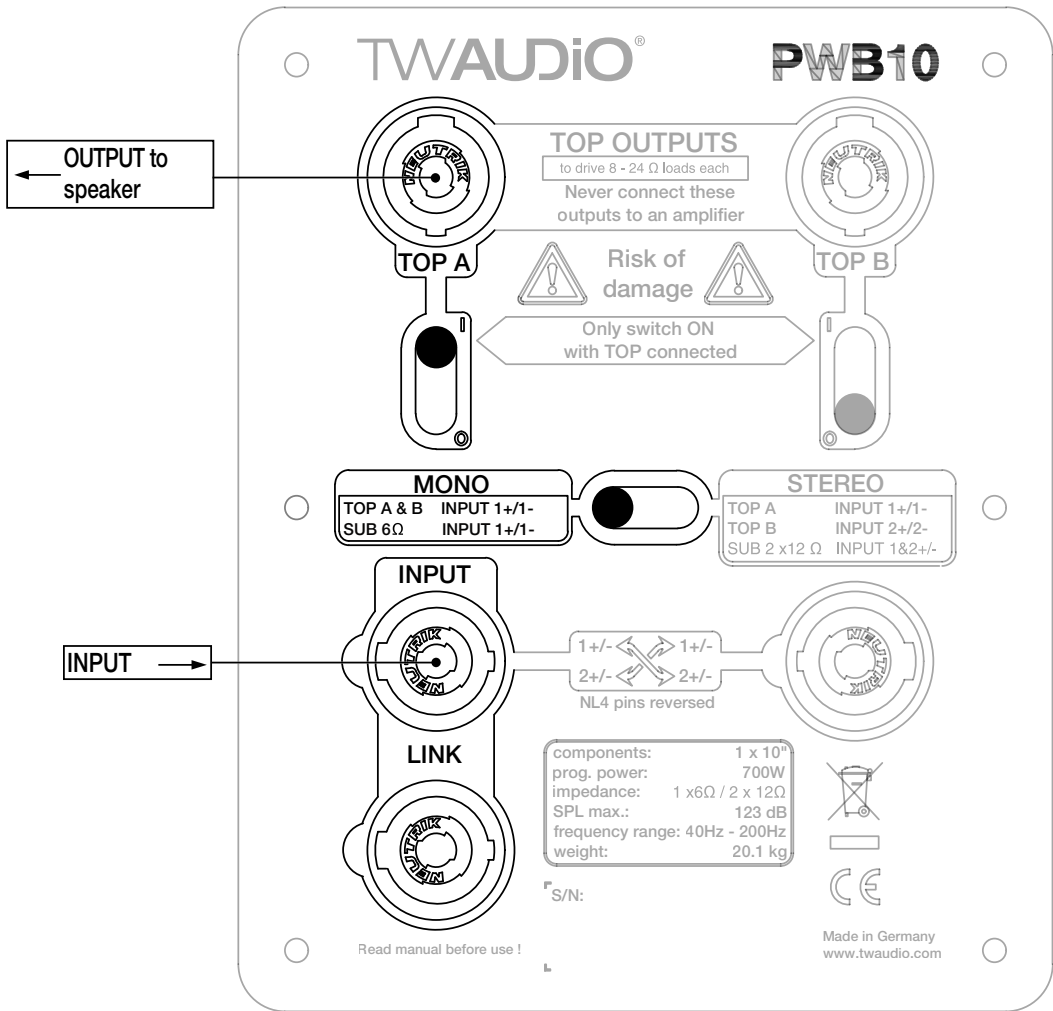

Figure 2.3.1.1 - Overview operation MONO

Two input channels are required for operation in „STEREO“ mode. The left input is assigned to pin 1+/-, the right input to pin 2+/-.



HINWEIS

If only single-channel cables (PIN 1+/-) are used, connect the left channel's cable to the "Input" connector. Connect the right channel's cable to the "Reversed" connector.

If a four-pin cable is used for both channels (L = 1+/-, R = 2+/-), connect this cable to the "Input" connector.

Never connect two amplifier channels to the "Input" and "Reversed" connectors using two four-pin cables at the same time, as this may short-circuited and damage the amplifier.



WARNING

1. Connect the top loudspeakers to the "high pass outputs" (TOP A and TOP B)! Never connect amplifiers to these connectors!
2. Switch the switch S3 to „STEREO“.
3. Switch the switches S1 and S2 to „ON“.

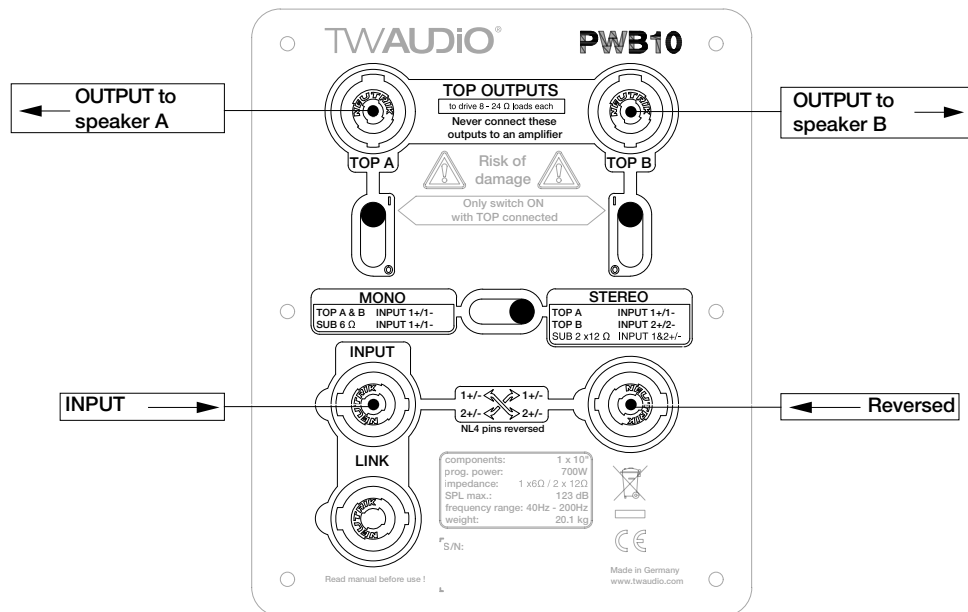

Figure 2.3.1.2 - Overview

2.3.2 Selector switch S1 and S2 - TOP OUTPUT mode

The two vertical selector switches (see figure 3.2.3 - S1 and S2) activate the respective high pass output. This makes it possible to connect and operate a mid/high range loudspeaker with a rated passive crossover of between 8 - 24 Ohms on the TOP OUTPUT outputs.



NOTE

Note that the total impedance may vary depending on the connected loudspeaker. See "Connecting the cable" on page 16.



NOTE

Never change the operation mode while the loudspeaker is in operation. This may damage the connected loudspeakers.

Operation mode 1 „ACTIVE“ additionally requires the correct preset at the amplifier.

3. Technical data

3.1 Data sheet

	Variant	
	B10A	B10P
Drivers	1x 10" LF	
Frequency response	40 - 400Hz	40 - 200Hz
Power handling (program/Peak)	700 / 1400W	700 / 1400W
Impedance	1x 8Ω (optional 2x 16Ω)	1x 6Ω or 2x 12Ω switchable
Max. SPL / 1 m	123dB	
Dimensions (h x w x d)	304 x 504 x 440mm [12,0 x 19,8 x 17,3in]	
Weight	16,1 kg [35,5lbs]	20,1 kg [44,3lbs]
Surface	Warnex textured paint	

3.2 Connection diagram

3.2.1 Variant: B10A

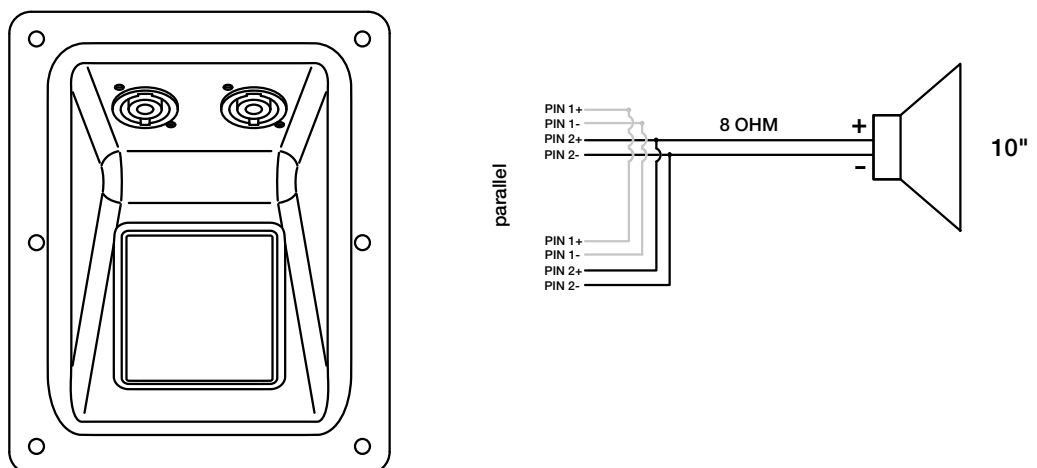

Figure 3.2.1 - Connection diagram B10A

3.2.2 Variant: B10P

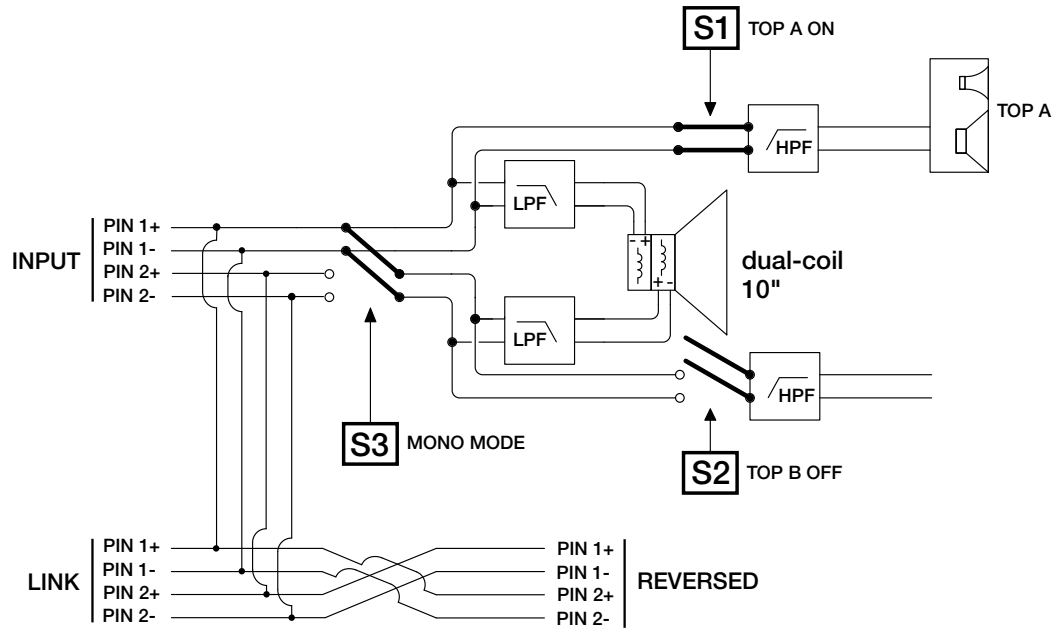

Figure 3.2.2.1 - Connection diagram B10P - MONO

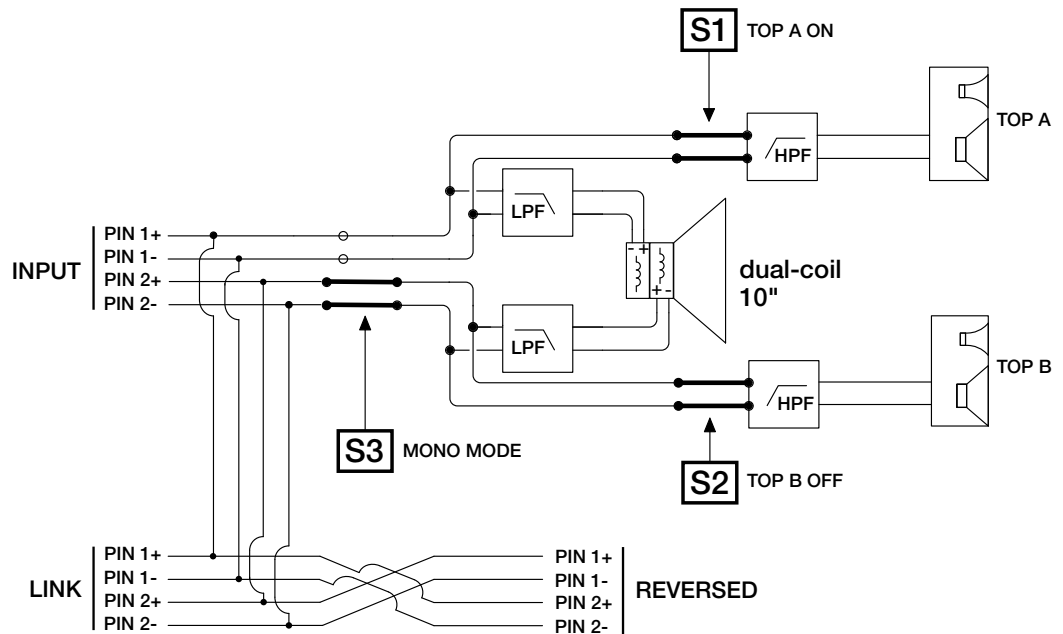

Figure 3.2.2.2 - Connection diagram B10P - STEREO

4. Commissioning

4.1 Setup

The B10 loudspeaker is designed for standing operation.



Make sure that all system structures are located on a firm, level surface and that the surface can bear the total weight!



Ensure that the loudspeakers are securely attached to prevent personal injury and property damage. Secure stacked loudspeakers properly so that they can be tipped by 10° in any direction without toppling.



TWAUDIÖ recommends using only the accessories specified by TWAUDIÖ for securing and mounting loudspeakers.

4.2 M20 pole mount flange

For all system components mounted on top of the M20 pole mount flange, observe the respective operating instructions!

Also be sure to observe all of the following warnings:



Make sure that the maximum load of 50kg / 110lbs for the M20 pole mount flange is not exceeded! Figure 2.1 – Item 3.



Make sure that no unauthorized persons can access the system structures!

Cordon off the area professionally!



The M20 pole mount flange (figure 2.1- item 3) is not designed for side forces once mounted – do not apply any pressure from the sides.

Make sure that no external forces are applied to the system structures. No objects or persons should lean against the structures, no objects such as balls should be thrown against them. If pressure is applied on the flange when mounted the loudspeaker may be damaged by falling over.



Before setting up the system outdoors, consider unexpected wind conditions at the operation site!

Disassemble your system immediately when wind speeds exceed 8 bft (34 to 40 kn / 62 to 74 kph / 38.5 to 46 mph) and secure the system components!

Make sure that there are no persons in the immediate vicinity of the system structure!



Make sure that the system structures are not operated over the audience at wind speeds in excess of 6 bft (22 to 27 kn / 39 to 49 kph / 24.2 to 30.45 mph) and that there are no persons in the immediate vicinity of the system structure!



Please note that only centered loads are allowed to be placed on the M20 pole mount flange – figure 2.1 – Item 3.

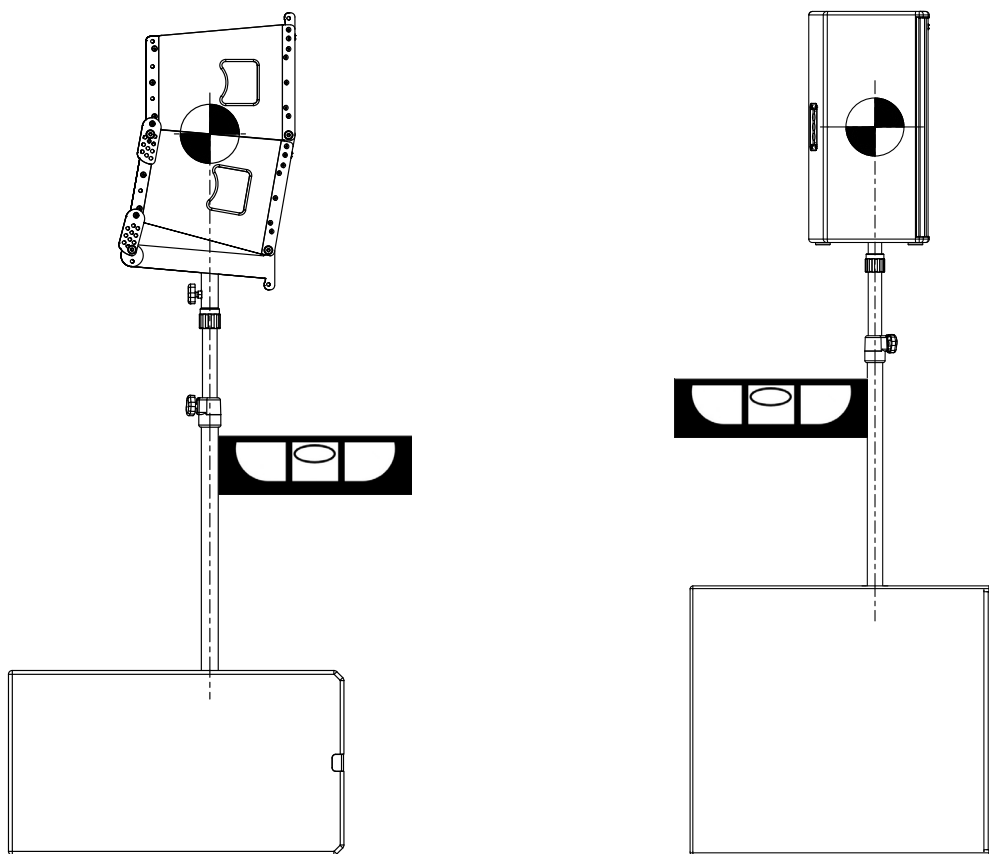

Figure 4.2.1 - system setup B10

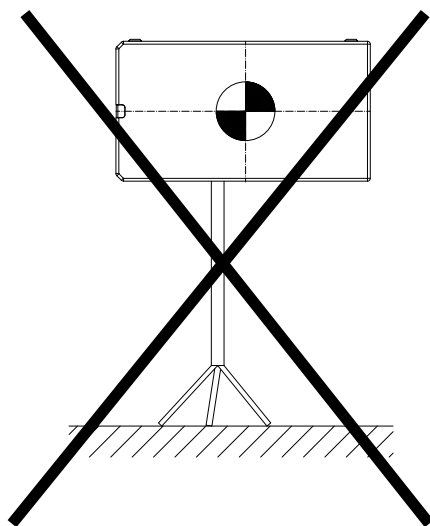

Figure 4.2.2 - B10 – improper installation

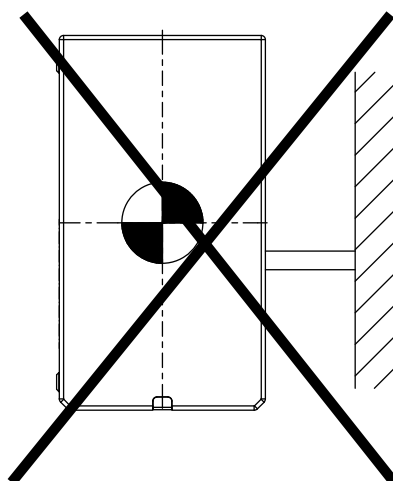

Figure 4.2.3 - B10 – improper wall mounting

4.3 Operation

Operation of the B10A speaker requires a DSP-Controller. TWAUDIÖ recommends operating the B10P loudspeaker on a DSP-Controller. For this purpose, only presets developed by TWAUDIÖ are recommended. The TWAUDIÖ system racks are ideally suited for this purpose.



NOTE

Before connecting the loudspeaker to the amplifier, ensure that the right preset has been loaded.

Using the wrong preset or a preset not provided by TWAUDIÖ preset can destroy the speaker.



NOTE

Make sure that the amplifier's specifications meet the requirements. Using an amplifier that doesn't meet the specifications can destroy the loudspeaker.

Please note the technical data in section 3.1 on page 11.

4.4 Connecting the cable

To create a cable connection with an amplifier rack from TWAUDIÖ, proceed as follows.



NOTE

Ensure that the cable cross sectional area is sufficient (at least 1.5 mm²) to avoid power losses. TW AUDiO recommends using the loudspeaker cables available from TWAUDIÖ.

When connecting the cables to the loudspeaker, ensure that polarity (+/-) and pin assignment (1/2) are correct. Incorrect connection can lead to a significant change in the loudspeaker's sound characteristics and may damage the driver.

The pin connections of the B10 loudspeaker can be found in section 3.2 ("Connection diagram") on page 11 and 12.

The internal wiring of the B10 loudspeaker allows for parallel connection of multiple loudspeaker units.

Please note that parallel connections will decrease the total impedance of your loudspeaker configuration.

The total impedance and the resulting power of the speaker configuration must match the output power of the amplifier.

5. Transport and storage

Due to the B10 loudspeaker weighing over 20kg [44.09lbs.], two persons are required to handle and transport the unit.



NOTE

To enable a single person to transport several multiple B10 loudspeakers, TWAUDIÖ recommends using the QDB10 quad dolly.

When transporting and storing the unit, it is important to ensure that the surface and front grill of the loudspeaker are not damaged. Moisture can penetrate through exposed wood surfaces and cause the wood to swell. A bent or broken front grill will no longer adequately protect the sensitive speaker membranes.

In addition, appreciable dust deposits may considerably impair the functionality of a loudspeaker membrane. For this reason, the loudspeakers should be transported and stored in a safe, careful, dry and largely dust-free manner.

The following accessory parts for transport and storage are available from TWAUDIÖ:

- QDB10 (Quaddolly)
- BagB10 (Carrying bag)

The original packaging is unsuitable as permanent storage and transport packaging.

6. CE Conformity Declaration

Copy and translation of the original CE Conformity Declaration:



We hereby declare that the below-referenced components by virtue of their design and construction, and in the configuration placed on the market by us, satisfy the safety and health requirements of the applicable EC directives. This declaration becomes invalid in case of modifications that have not been approved by us.

This declaration applies to the following components

- B10A
- B10P

as well as all model variants based on these, provided that they correspond to the original factory models and have not been technically modified in any way.

Applicable directives:

- 2001/95/EG
- 2011/65/EU

Applicable national standards and technical specifications:

- DIN EN 18800
- DIN EN ISO 12100
- BGV C1 / BGI 810-3
- EN 50581: 2013-02

Ludwigburg, Germany, January 1st, 2017

A handwritten signature in black ink, appearing to read 'T. Wüstner', with a horizontal line drawn through it.

Tobias Wüstner

7. Disposal

It is prohibited to dispose of used electrical equipment with household refuse.



All TWAUDIÖ GmbH products are so-called B2B-products. This means that they are sold by a commercial business to a commercial business. TWAUDIÖ products that bear the trash can symbol shown here may only be disposed of by TWAUDIÖ.

The loudspeaker owner is legally responsible for proper disposal of used devices that do not bear this symbol. This pertains to all products delivered prior to March 29, 2010. Nevertheless, TWAUDIÖ will also be happy to assist you in this case.

If you have any question regarding the disposal of used devices, please contact us under the following telephone number:

+49 (0) 71 41 - 48 89 89 0

Thus, TWAUDIÖ is in strict compliance with the Waste Electrical and Electronic Equipment Directive (2012/19/EU) for the protection of our environment.

TWAUDIÖ is registered under the following WEEE-reg.-no. with the German National Register EAR as a B2B-manufacturer and distributor of electrical devices:

DE54488702

In countries outside of the European Union, comply with local regulations.

TWAUDIÖ GmbH
Osterholzallee 140
71636 Ludwigsburg
Germany

Phone : + 49 (0) 71 41-48 89 89 0
Fax: + 49 (0) 71 41-48 89 89 99
E-Mail: info@twaudio.de
WWW: www.twaudio.de